

harmoni

INSTALLATION MANUAL

harmoni cable

LIFETIME
WARRANTY

INSTALLER
WARRANTY



FI



Before you begin installing, read through these instructions carefully and check that you have all the components required.

www.harmoniheating.co.uk

01473 559088

INTRODUCTION

Important notes, please read carefully before proceeding with installation

The Harmoni brand

Congratulations on choosing the cable underfloor heating product from the Harmoni range of underfloor heating solutions.

The Harmoni range has been manufactured to exceed all relevant standards and expectations considering ease of installation and usability through the lifetime of the product.

Harmoni Cable

The cable is a thin (5.5mm) twin conductor, PVC-free 20W per linear metre constant wattage heating cable with a pre-terminated 2.5m cold tail (power cable) attached.

The cable is designed for installation in concrete floors and slabs of new builds, or outdoors in driveways, parking areas, gutters and snow melting on roofs. cable is also suitable for large areas, indoors and outdoors, such as green houses, sports fields or factories.

Tools needed for installation

The following items are needed to install and test the cable system:

- Tape measure drawing pad and pencil
- Cable strippers and screw driver
- Resistance tester (multimeter)
- Hammer & masonry nails

Contents of cable system

- Heating cable
- Sensor tube
- Installation instructions
- Warranty

Examples of wattage requirements

Wattage requirements will depend on the application. The following can be used as a general guide:

- a) Concrete flooring..... 150W per m²
- b) Ramps, walkways, driveways..... 250W per m²
- c) Greenhouses, sports halls..... 150W per m²

Please note the wattage values shown above are meant as a general guide only. Actual requirements will depend on insulation levels, floor construction, type of floor coverings, ambient temperature, movement of people, etc.

Dos & Don'ts

Do

Carefully read this instruction manual before starting your installation and **follow the testing procedure on page 9.**

- Plan your cable layout considering all obstacles, e.g. drain covers, kitchen units bathroom sinks etc, using the grid on pages 10–11.
- Ensure the floor sensor thermostat is inserted within the flexible tube provided, with the floor end of the flexible tube properly sealed (to ensure easy removal of the floor sensor after installation if required).
- Take care not to damage the heating cable and cold tail (power cable) whilst screeding the floor area.
- Ensure the entire blue heating element is installed within the floor and covered with the sand cement screed or flexible self-levelling compound.
- Ensure the floor surface is correctly prepared before installation (*see page 4*).
- When using more than one cable from a single supply, cold tails must be connected in parallel.
- After installing the heating system, allow 6–8 weeks for the floor/slab to dry/cure before switching on the heating system.
- Ensure all the cables are evenly spaced across your complete free floor area.

Don't

- Don't cut, shorten or alter the blue heating cable: this can cause over heating, resulting in damage to the cable.
- Don't cross or touch the blue heating cable: this can cause the cable to overheat.
- Don't lay directly onto polystyrene Jablite insulation without separating with a chicken wire mesh, minimum 12 gauge.
- Don't install the heating cable below –10°C ambient temperature.
- Don't connect the heating element to the power supply whilst the heating cable is still coiled.
- Don't leave coiled sections of heating cable under the floor screed – ensure all heating cable is evenly spaced across the free floor area.
- Don't commence installation of your floor surface before testing your cable (*see page 9*).
- Don't screed over damaged or twisted cables.
- Don't install heating cables closer than 50mm.
- Don't place flush fitting furniture, including bean bags, rugs or mats on the floor where heating cables are situated.
- Don't install on stairs or irregular surfaces.

CONSTRUCTION OF THE HARMONI CABLE

SGS Fimko certified as per standard IEC 60800:2009 (Ed 3)



The cable is comprised of a single-strand or coiled heating element within a primary insulation of Fluoropolymer (FP), wrapped in a metal braid and an outer jacket of polyolefin, which terminates on a cold lead of 2.5m length.

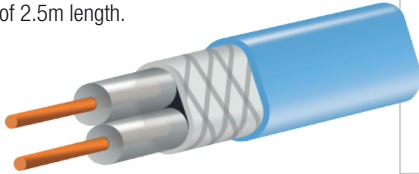

- A** Heating element
- B** Factory made cold tail joint
- C** Cold tail power lead
- D** End termination joint

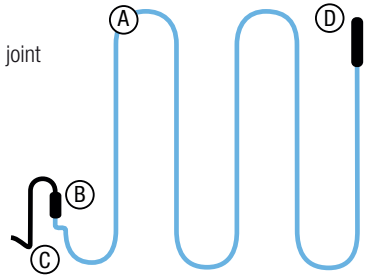

ELECTRICAL REQUIREMENTS

Always consult a qualified electrician regarding your requirements

Please follow these instructions carefully. If you require assistance prior to or during your installation, please call our helpline on 01473 559088

Important Notes

The heating system installation wiring must be in accordance with the national wiring rules. See below for a list of controls and accessories we recommend to use with the floor heating cables.

- Floor sensing temperature controller/thermostat
- GFCI (ground fault circuit interrupter)/(RCD) residual current device
- Main switch

The floor heating system shall be connected to a main switch for complete disconnection.

The thermostat/connection box should be positioned flush to the wall surface, about 1.2m (4ft) up from the floor for easy access and setting. Route the floor sensor cable and the heating cable cold leads to the thermostat/power connection box in separate conduits.

In case the heating system load is below 3.2KW, based on thermostat power rating, it can be connected directly to a control electronic thermostat, as per the diagram on the right, which shows a typical scheme of an electrical system. If the heating system load is more than the thermostat power rating, you must consult a qualified electrician for the scheme.

List of accessories required in addition to the heating cables:

- Floor sensing programmable thermostat (see below)
- Main switch
- Residual current device (RCD)

Note:

Details of the thermostat installation will be available in the installation manual provided with the thermostat.

Controls

- Thermostat: OJ Electronics OCC2

GFCI (Ground Fault Circuit Interrupter)/Residual Current Device (RCD) or equivalent having a rated residual operating current not exceeding 30mA is recommended for protection against earth leakage currents.

For a 3.2KW load a 16A GFCI/RCD is required. Please consult a qualified electrician for selecting a GFCI of suitable rating based on the floor heating system or any other protection equipment as per the applicable local rules and regulations.

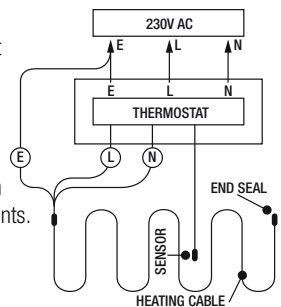

This symbol means **Direct Floor Heating**

PRE-INSTALLATION INSTRUCTIONS

Ensure the sub-floor is structurally sound, clean and dry before you begin



Ensure the cable is the correct size before unpacking the product.
Call 01473 559088 if you have any questions.

⚡ Important Notes

Keep an accurate record of where the cables are installed to assist you for future reference, (e.g. during renovation work).

Part P wiring regulations state that a diagram must be placed next to your fuseboard showing where underfloor heating is installed.

Step 1: Planning

Using the grid on pages 10–11, draw a layout of your room – include all obstacles, e.g. drain covers, toilets, sinks etc – then determine the required floor area to be heated.

Decide a suitable position for the thermostat (start point) then calculate your cable spacing and layout (*see page 7*).

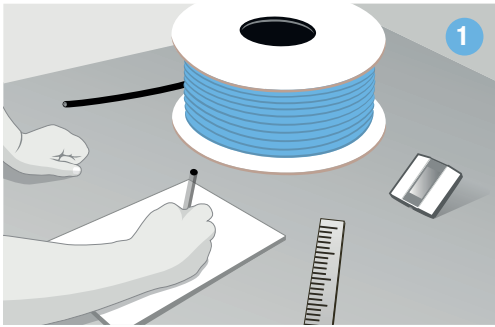

Step 2: Install underlay/insulation boards

Prepare the floor ready for the cable installation. Remove all loose particles, thoroughly clean the floor then treat with any proprietary sealants as normally required.

If your existing floor has a bitumen or asphalt surface it must either be removed or covered with a thin flexible self-levelling compound, sand cement mix or foil faced insulation panels. If installing foil faced insulation panels do so in accordance with the manufacturer's instructions.

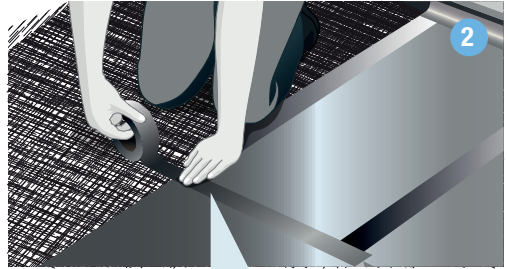

Ensure all joints are properly taped & sealed to prevent the cable from slipping in-between insulation panels.

Step 3: Install the flexible tube

Directly below the electrical connection point install a 10mm flexible tube. The flexible tube must be situated in-between two cable runs (*see step 6*).

The floor sensing probe is installed into the flexible tube to monitor the floor temperature. Ensure the tube is installed to allow easy replacement of the sensor probe in case it fails.

- Seal the flexible tube to prevent sand/cement mix or self-levelling compound entering the tube.
- Secure the flexible tube in position with a section of fixing strip or robust utility tape.

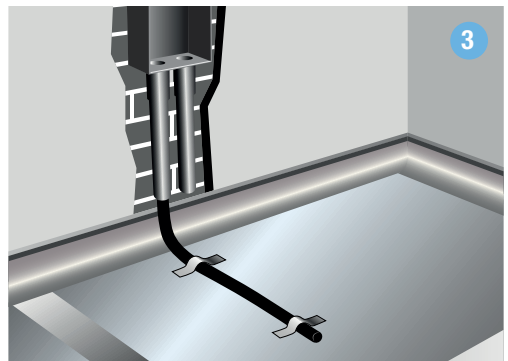

INSTALLATION INSTRUCTIONS

Read through these instructions carefully before laying your cable

Step 4: Install the fixing strip

The fixing strip should then be anchored to the floor running perpendicular to your proposed heating cable layout and spaced evenly every 750mm.

The fixing strip fastening will vary depending on your floor base.

- Fix on to a concrete slab use masonry nails.
- Fix onto foil faced insulation panels use a robust utility tape.

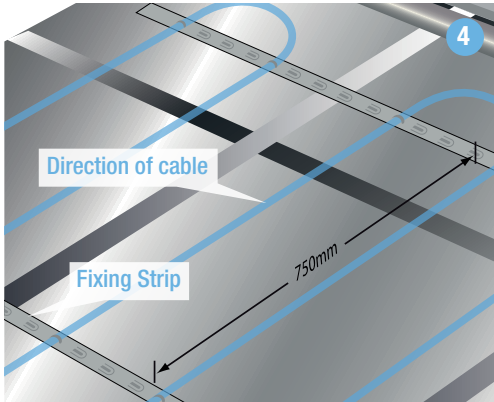

⚡ Important Note

Now perform the following tests (see page 9):

- Insulation resistance test
- Heating cable resistance test
- Thermostat floor sensor resistance test

The findings must be recorded on the *Commissioning Record* enclosed in the cable box or your warranty will be invalidated.

Step 5: Connect the floor sensor cable

Remove the securing tape from the cable roll and position at the start of your cable plan with the cold tail (power cable) at the electrical back box.

Ensure the separate thermostat floor sensor cable is inserted into the pre-installed 10mm flexible tube and returned to the low level electrical back box.

The cold tail joint must be positioned in the floor area.

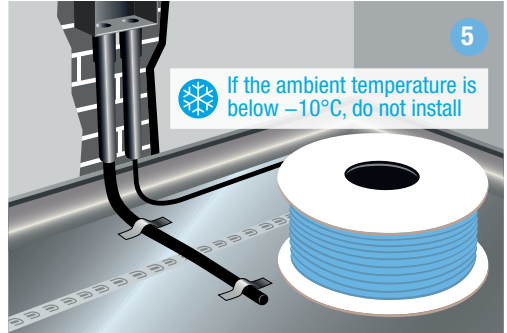

Step 6: Lay the cable

Once the cable cold tail (power cable) and thermostat floor sensor probe have been positioned you can now start to lay your cable.

Following your previously drawn cable layout and spacing, continue to lay and secure your cable on to the pre-installed fixing strip. Continue laying cable until total floor area is covered. All heating cable must be used, any excess heating cable must be reconfigured into the floor area by adjusting your cable spacing. Ensure all heating cables are evenly spaced across the floor area.

- Do not cut any surplus heating cable.
- Do not leave any excess heating cable spooled or coiled in the floor area.
- Ensure the cables are not laid in areas where fixed appliances will be positioned, e.g., underneath sink basins or toilet pans.
- Do not over tape cold joint and end seal.

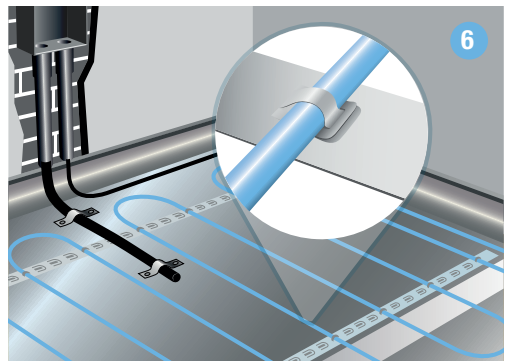

INSTALLATION INSTRUCTIONS

Read through these instructions carefully before laying your mat

- ⚡ Just before laying the floor screed check the resistance of the cable again (*see page 9 for details*) to make sure damage hasn't occurred during the installation process.

Step 7: Lay the floor screed

Now that all your heating cable is correctly laid into your floor area you can begin to lay your floor screed. Ensure your floor screed is laid in accordance with your local building control requirements and take care not to damage the heating cable.

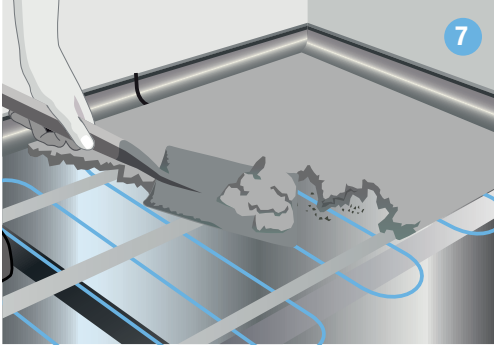

⚡ Important Notes

- Take care not to damage the heating cable.
- Do not disturb the cables from their pre-placed spacing.
- The cables must never be cut or trimmed to fit into a space that is too small.
- Care should be taken to avoid damage during installation, such as dropping heavy or sharp objects, stepping on the cables or careless laying of the screed.

 Always allow 6–8 weeks for complete curing of the floor screed before switching on your system.

 Don't place flush fitting furniture, including bean bags, rugs or mats on the floor where cable is situated.

Product specifications

Quick Find	Part Code	Length	Wattage	Resistance @20°C (-4/+9%)
16408	HMC425	20m	425w	125.0 Ω
16409	HMC650	32m	650w	81.4 Ω
16410	HMC830	40m	830w	63.7 Ω
16411	HMC970	50m	970w	54.5 Ω
16412	HMC1270	60m	1270w	41.7 Ω
16413	HMC1410	70m	1410w	37.5 Ω
16414	HMC1620	80m	1620w	32.6 Ω
16415	HMC1890	90m	1890w	28.0 Ω
16416	HMC2530	125m	2530w	21.0 Ω

⚡ Important Note

The maximum thermal resistance recommended between heater and the room is 0.15m² K/W (1.5 tog).

After the finished floor covering has been laid, perform the following tests again (*see page 9*):

- Insulation resistance test
- Heating cable resistance test
- Thermostat floor sensor resistance test

The findings must be recorded on the *Commissioning Record* enclosed in the mat box or your warranty will be invalidated.

CABLE SPACING & LAYOUT INSTRUCTIONS

Calculate the cable spacing and work out the layout

It is important when calculating your cable spacing to accurately draw your room area as this will help to save time and ensure a smooth installation. Use the grid on pages 10–11 to sketch your floor plan.

1. Draw your total room area including all fixed furniture such as kitchen units, sink areas and toilets (fig 2). Mark your drawing with relevant dimensions (fig 1).
 2. Calculate the **total area** by multiplying the length and width of room. If your floor is an unusual shape it helps to divide the area into square sections and add the sections together (fig 1, part a).
 3. Calculate the **perimeter** by adding the lengths of all the walls together (fig 1, part b).
 4. A border of 100mm must be maintained between the edge of the wall and the cable. Calculate the **border area** by multiplying the border width (0.1m) with the perimeter (fig 1, part c).
 5. Calculate the **free floor area** by subtracting the border area from the total area (fig 1, part d).
 6. Finally, find the **watts per m²** by dividing the cable size, indicated on your product, by the free floor area (fig 1, part e).
 7. Once you have calculated your watts per m² refer to the Cable Space & Wattage Chart A (see page 8) to find your ideal cable spacing: i.e. 180 watts per m² = 111mm.
 8. The pre-spaced fixing strip has cable spacing every 25mm therefore we need to refer to our Cable Spacing Chart B (see page 8) to find our nearest actual cable spacing.
 9. Our 111mm ideal cable spacing becomes 112.5mm (nearest average spacing), so the spacing for your cable will be 1 space at 100mm (5 segments of 25mm) and 1 space at 125mm (6 segments of 25mm) = Average 112.5mm.
- Repeat this pattern as per diagram in fig 2.

FIG 1

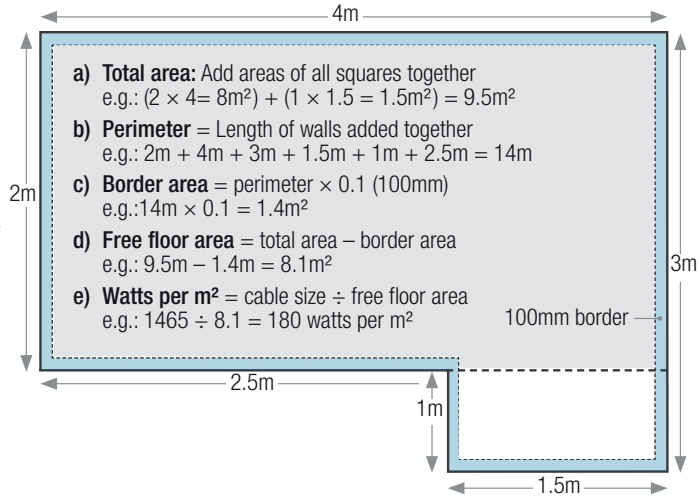
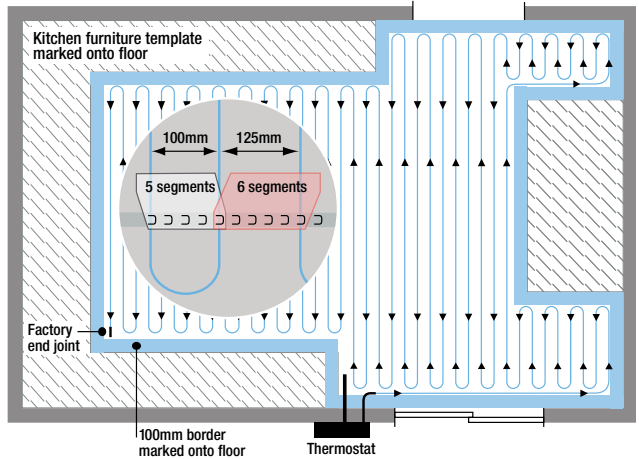

FIG 2



- Calculate your **Cable Spacing & Total Load** on page 8
- Sketch your **Floor Plan** using the grid on pages 10 & 11



CABLE SPACING & WATTAGE

Calculate cable spacing, wattage and total load

Chart A: Cable space and wattage per m²

Installed W/m ²	Spacing mm	Installed W/m ²	Spacing mm	Installed W/m ²	Spacing mm	Installed W/m ²	Spacing mm
133	150	162	123	191	105	220	91
134	149	163	123	192	104	221	90
135	148	164	122	193	104	222	90
136	147	165	121	194	103	223	90
137	146	166	120	195	103	224	89
138	145	167	120	196	102	225	89
139	144	168	119	197	102	226	88
140	143	169	118	198	101	227	88
141	142	170	118	199	101	228	88
142	141	171	117	200	100	229	87
143	140	172	116	201	100	230	87
144	139	173	116	202	99	231	87
145	138	174	115	203	99	232	86
146	137	175	114	204	98	233	86
147	136	176	114	205	98	234	85
148	135	177	113	206	97	235	85
149	134	178	112	207	97	236	85
150	133	179	112	208	96	237	84
151	132	180	111	209	96	238	84
152	132	181	110	210	95	239	84
153	131	182	110	211	95	240	83
154	130	183	109	212	94	241	83
155	129	184	109	213	94	242	83
156	128	185	108	214	93	243	82
157	127	186	108	215	93	244	82
158	127	187	107	216	93	245	82
159	126	188	106	217	92	246	81
160	125	189	106	218	92	247	81
161	124	190	105	219	91	248	81
						249	80
						250	80

Chart B: Combinations to achieve average space

Spacing	Combination
58	2@50mm, 1@75mm
62	1@50mm, 1@75mm
67	1@50mm, 2@75mm
83	2@75mm, 1@100mm
87.5	1@75mm, 1@100mm
92	2@100mm, 1@75mm
108	1@100mm, 1@125mm
112.5	1@100mm, 1@125mm
117	1@100mm, 2@125mm
133	2@125mm, 1@150mm
138	1@125mm, 1@150mm
142	1@125mm, 2@150mm

Calculator

Calculate your total load

.....

.....

.....

.....

.....

.....

.....

.....

.....

Total Load

TESTING & COMMISSIONING

The warranty validation procedure must be carried out to validate the warranty



Warranty Validation

To validate your lifetime warranty registration you must perform the insulation resistance test, the heating cable resistance test and the sensor resistance test three times during the installation process.

1. Before you lay the cable.
2. After you have laid the cable and before you cover it.
3. After your finished floor has been laid.

This information must be recorded on your *Commissioning Record* (enclosed in the cable box), otherwise the warranty will be invalidated.

Heating Cable Resistance Test

This test is carried out to prove continuity of the heating element. A low resistance ohm meter should be used (i.e. Multimeter on ohm setting), connect your meter on to the brown and blue mains lead and confirm resistance value matches that quoted on your specification label on the cable cold lead joint.

Floor Cable Resistance Test

As per the *Heating Cable Resistance Test* above but repeat with floor sensor cable.

Insulation Resistance Test

This test is performed to measure the insulation resistance between conductors and ensures the cable insulation is not damaged. A low resistance reading indicates a damaged cable and must be repaired or replaced.

The insulation resistance tester should be connected between the conductors (blue and brown cables) and the earth (yellow/green cable). The meter should record a high resistance value e.g. above 100 Meg ohms.

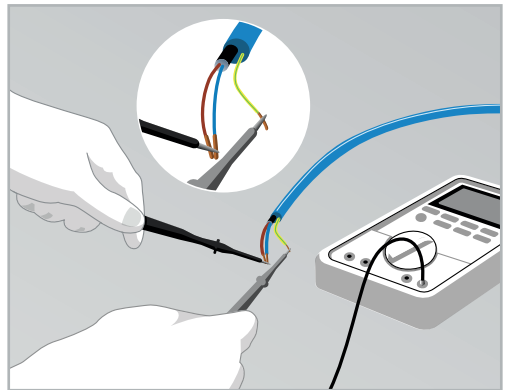
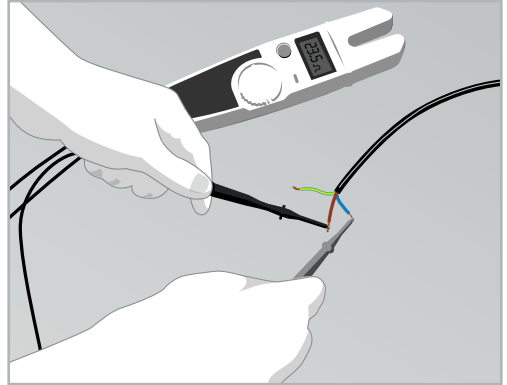

Important Note

The Commissioning Record must be placed adjacent to the distribution board and must contain the location of the installed underfloor heating.



FLOOR PLAN SKETCH

Calculate your total heat area

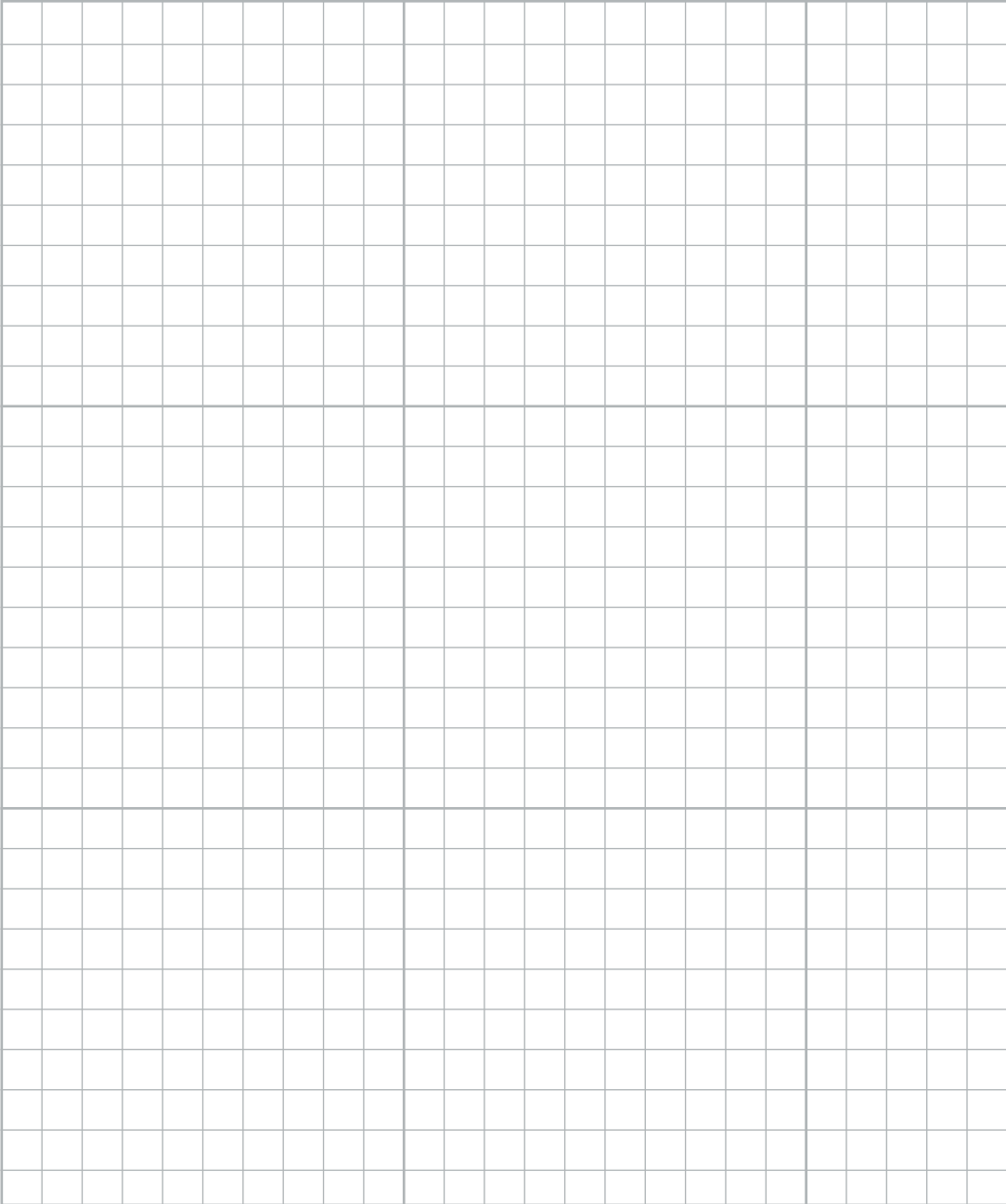

FLOOR PLAN SKETCH

Calculate your total heat area

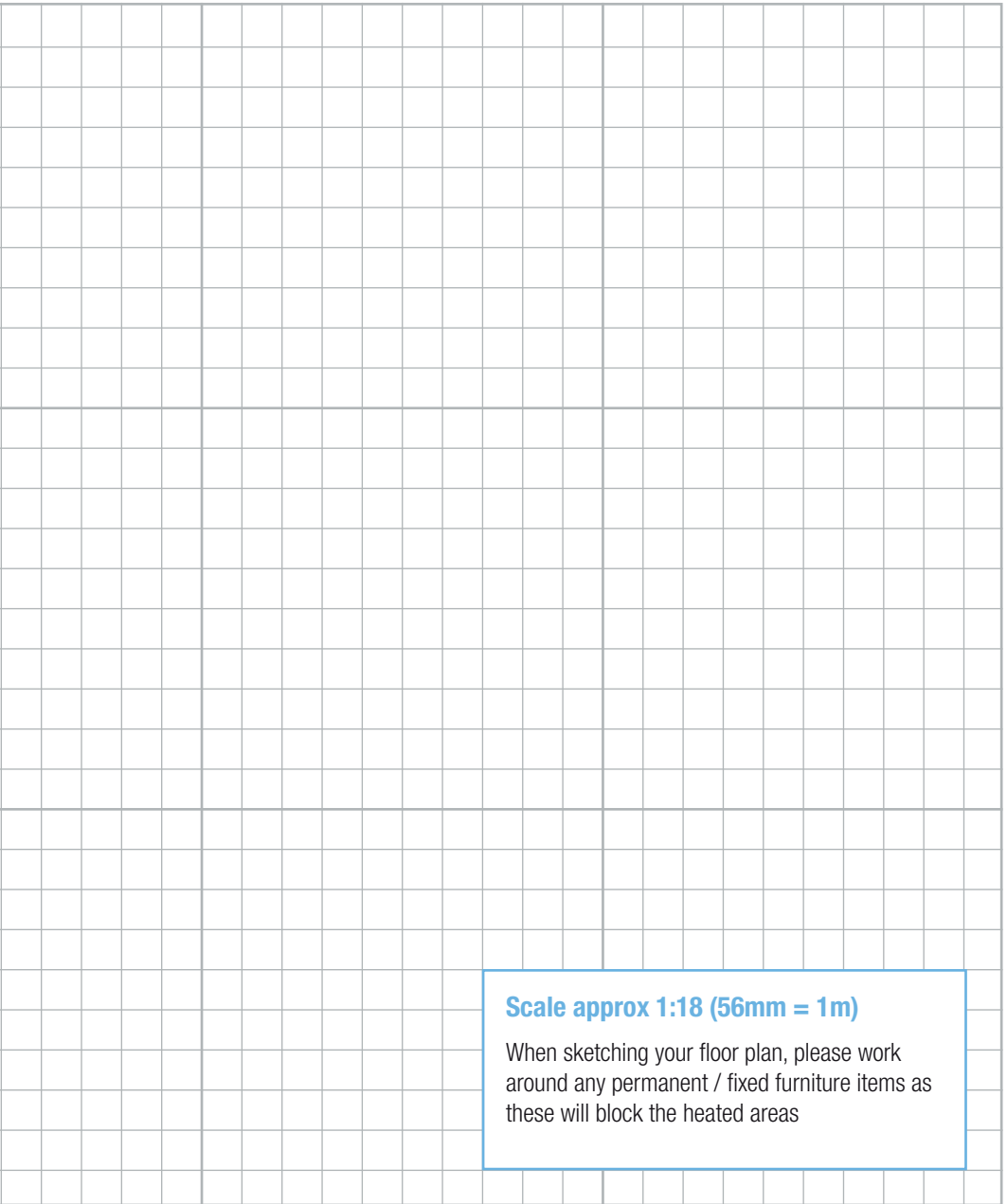
A large grid for drawing a floor plan sketch. The grid is composed of small squares, with a larger square grid pattern overlaid on it. The larger squares are approximately 10 units wide and 10 units high. The smaller squares are approximately 1 unit wide and 1 unit high. The grid is intended for sketching a floor plan.

Scale approx 1:18 (56mm = 1m)

When sketching your floor plan, please work around any permanent / fixed furniture items as these will block the heated areas

TROUBLESHOOTING

Refer to the table below and contact us with any questions on 01473 559088

Symptom	Probable Causes	Corrective Action
Floor does not heat	No power at controller	Check power supply
	RCD/MCB tripped	Check the circuit is not overloaded
	Thermostat not set correctly	Refer to thermostat instructions
	Cable not correctly connected with thermostat	Refer to thermostat instructions
	Floor temperature sensor not connected	Refer to thermostat instructions
	Faulty sensor/thermostat	Contact the Harmoni Helpdesk 01473 559088
Floor warming all the time	Heating element cut or damaged	Contact the Harmoni Helpdesk 01473 559088
	Thermostat not set correctly	Refer to thermostat instructions
Floor not getting warm enough	Floor temperature sensor not connected	Refer to thermostat instructions
	Thermostat not set correctly	Refer to thermostat instructions
Floor not getting warm enough	Floor sensor too close to heating element	Contact the Harmoni Helpdesk 01473 559088

Contact the Harmoni Helpdesk with any questions on 01473 559088

NOTES

Use this space to make notes for reference

Edison House
Edison Close
Ransomes Europark
Ipswich, Suffolk IP3 9GU

Tel: 01473 559088
Fax: 01473 559076
Email: sales@harmoniheating.co.uk
Web: www.harmoniheating.co.uk

harmoni

